



Surface Mount



Ceiling Mount

Surface and ceiling mountable without additional accessories

The Hybrid LED Exit Sign combines Ecoglo's internationally recognised photoluminescent technology with Class II LEDs and the next generation patented electronics.

Requiring no battery backup, the internally illuminated photoluminescent exit sign is effective in all lighting scenarios. Designed to be used in and about buildings to identify escape routes for compliance with performance based building codes, the signs will be clearly visible and readily understandable under all conditions of foreseeable use, including emergency conditions.

COMPLIANCE

Ecoglo Hybrid LED Exit Signs can be used in Performance Solutions to meet the requirements of building codes such as NFPA 101 Life Safety Code, International Fire Code (IFC), Building Code of Australia (BCA), and any other performance based building codes.

PERFORMANCE

Provides a minimum of 90 minutes of visibility after failure of the main lighting.

INPUT

230/240 Vac, 50/60 Hz, Single and Double Sided Sign

RATED POWER CONSUMPTION

0.5W Single and Double Sided Sign

SUPPLY

The signs are currently available in one size. See table for maximum viewing distance of each sign.

Signs with black housing are also available - contact Ecoglo for more information

PRODUCT CODE	PRODUCT DESCRIPTION	GRAPHICS INCLUDED	MAXIMUM VIEWING DISTANCE
HYU1.2	Single Sided Hybrid Sign	1 x RM, 1 x RMR, 1 x RML	16 metres
HYU1.2-RMRL	Single Sided Hybrid Sign	1 x RM Double Arrow	16 metres
HYU1.2-RMB	Single Sided Hybrid Sign	1 x RM Low Light Black	16 metres
HYU1.2-EXB	Single Sided Hybrid Sign	1 x Exit Low Light Black	24 metres
HYU1.2-EX	Single Sided Hybrid Sign	1 x Exit	24 metres
HYU1.2-EXR	Single Sided Hybrid Sign	1 x Exit Right	16 metres
HYU1.2-EXL	Single Sided Hybrid Sign	1 x Exit Left	16 metres
HYU2.2	Double Sided Hybrid Sign	2 x RM, 1 x RMR, 1 x RML	16 metres
HYU2.2-RMRL	Double Sided Hybrid Sign	2 x RM Double Arrow	16 metres
HYU2.2-EX	Double Sided Hybrid Sign	2 x Exit	24 metres
HYU2.2-EXRL	Double Sided Hybrid Sign	1 x Exit Right, 1 x Exit Left	16 metres
HYU2.2-EXB	Double Sided Hybrid Sign	2 x Exit Low Light Black	24 metres

Above signs include one or more of graphics shown below.

Note: Custom graphics can be produced to suit regional requirements.



RM
Exit straight on from here



RML
Exit left from here



RMR
Exit right from here



RM DOUBLE ARROW
Exit right or left from here



RM (Low Light)
Exit straight on from here



EXIT (Low Light)
Exit straight on from here



EXIT
Exit straight on from here



EXIT LEFT
Exit left from here



EXIT RIGHT
Exit right from here

PRODUCT FEATURES

- LED/Photoluminescent Exit Sign System
- Meets most performance based international building codes.
- No batteries or backup power required for power outages
- High efficiency low power consumption LED charging source
- Long life LEDs (>100,000 hours)
- Works in all lighting scenarios
- Non-toxic, non-radioactive photoluminescent technology
- UL 924 tested and listed models available
- UL certified for 120 minute operating time at 16 metres. 24 metres model also available

INTERNAL SPECIFICATIONS

AC LED: standard 230/240 VAC input

PRODUCT DIMENSIONS

Height: 221mm
Width: 362mm
Depth: 62mm

PRODUCT WEIGHT

Single Sided Sign: 1.30kg
Double Sided Sign: 1.45kg

COMPREHENSIVE WARRANTY

15 years.

PROTECTION RATING

IP44 - Splashproof
(Suitable for outdoor environments where there is overhead protection such as a building eave or canopy, but should not be installed in fully exposed outdoor locations.)

INSTALLATION

The sign can be fixed directly to the ceiling or wall using the moulded mounting holes on each end of the sign.

Operating Temperature Range: 0°C to 40°C
When installed in our IP65 housing the operating temperature range is -20°C to +40°C
Contact Ecoglo for more details.

- BR3-CR.WHT (white ceiling recess kit)
- BR3-FM.WHT (white flag mount kit)
- BR3-EXHS.WHT (white weatherproof exit enclosure)

Installation needs to be carried out strictly in accordance with Ecoglo installation instructions. Consult installation instructions on website for full details.

CEILING AND WALL MOUNT

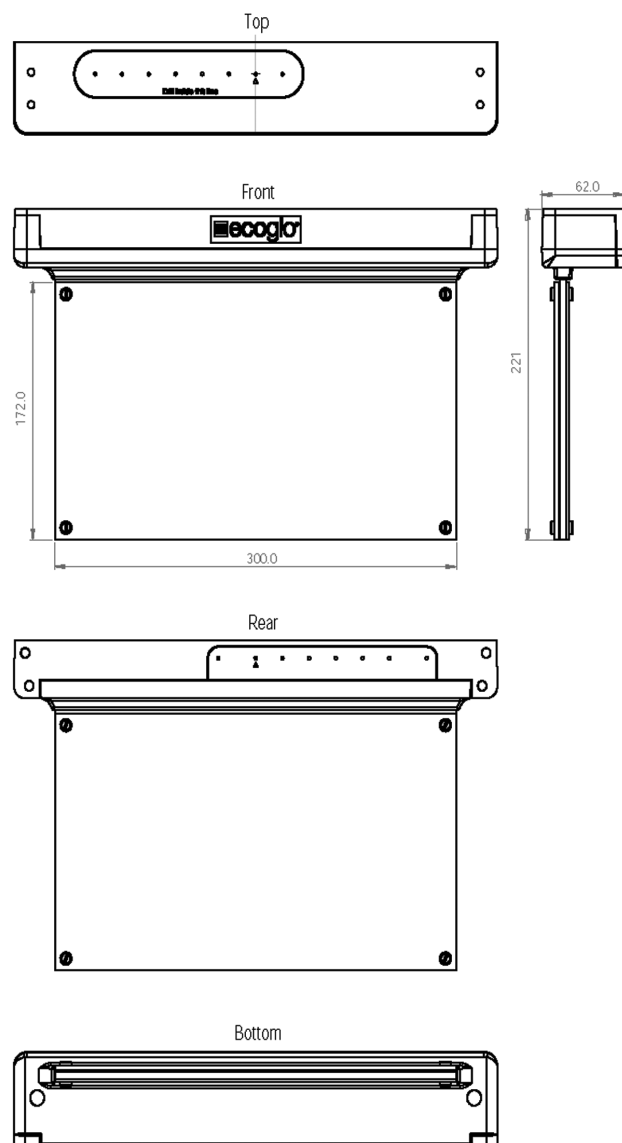

Contact

Ecoglo Fire Protection Product Trading

Address: 36-C Gloria Street, Barangay San Carlos, Binangonan Rizal 1940, Philippines

Office: +632-8802-4760

Cell: +63917-514-6803

+63968-356-4773

Email: keith.phillips@ecoglo.com

Web: www.ecoglo.ph www.EcogloAsia.com www.EcogloVenues.com